

August 19, 2010

# ***Drafting Requirements for the Preparation of Plans***

**NOTE:**

***This document is a Controller of Surveys Policy manual to be used as a general guideline for the preparation and examination of plans. Reference should still be made to the various Acts and Regulations pertaining to specific situations, which may or may not be included in this document.***

## **Table of Contents**

|  | <b>Page #</b> |
|--|---------------|
| <b>Overview</b> .....                  | <b>2</b>      |
| <b>Plan Format</b> .....               | <b>2</b>      |
| <b>General Plan Requirements</b> ..... | <b>5</b>      |
| <b>Legends</b> .....                   | <b>5</b>      |
| <b>Monuments</b> .....                 | <b>7</b>      |
| <b>Details</b> .....                   | <b>7</b>      |
| <b>Curve Information</b> .....         | <b>8</b>      |
| <b>Areas</b> .....                     | <b>10</b>     |
| <b>Parcel Designations</b> .....       | <b>10</b>     |
| <b>Natural Boundaries</b> .....        | <b>12</b>     |
| <b>Miscellaneous</b> .....             | <b>13</b>     |

---

# Overview

This goal of this document is to provide a set of Provincial drafting standards for plan preparation that applies to all plan types created under the Land Surveys Act 2000.

---

## Plan Format

1. A plan shall not exceed 860 mm in width or 3,000 mm in length. The GIS area covered by the plan shall not exceed 36 square miles. It is preferable that plans do not exceed one township or range in length. *Plan Size*
2. An area of at least 20 mm but no more than 40 mm in width around all edges of a plan shall be kept clear of any information. *Borders*
3. A title block shall appear on every graphic plan. The text should be oriented in the same manner as the text shown on the plan. This eliminates the need to rotate plan images in order to read the title block. Refer to the plan type documents for information on title block content. *Title Blocks*
4. Addresses and telephone numbers shall not appear anywhere on a plan. *Advertising*
5. All plans submitted shall be clear in detail, complete as to information and shall scale accurately. The standard plan scale shall be 1:5,000, 1:2,000, 1:1,000, 1:500, 1:200, 1:100 or a scale pre-approved by the Controller of Surveys. *Scales*
6. Plans that reproduce illegibly or in a faint manner will be returned to be redrawn or re-plotted. **Freehand drawing is not permitted on a plan without the prior approval of the Controller of Surveys.** *Illegible Plans*
7.
  - a) All road allowances on a plan shall be shown as solid lines. *Line Types*
  - b) All titled boundaries such as quarter lines, legal subdivisions, source parcels, etc shall be defined by solid lines
  - c) All Feature Plans filed in the Land Surveys Directory shall be shown as dashed lines. Easement Instruments or registered interests shall not be shown on the new plan unless they are represented by a plan within the Land Surveys Directory.
8.
  - a) The full extents of the source parcel shall be shown as solid lines and at a standard scale as specified in item 5. If this is not possible, the extents of the source parcel should be shown on a key plan. *Source Parcels & Key Plans*

- b) Key plans should be drawn to scale. If they are drawn to a standard scale as specified in item 5, the scale shall be displayed. If the key plan is drawn at a non-standard scale, the scale shall **not** be displayed. The notation “Not to Scale” shall **not** be shown on the key plan.
  - c) Feature plans may be omitted from key plans except when the feature plan is the purpose of the plan.
9. At minimum, portions of all parcels (including converted Metes and Bounds plans) immediately adjacent to the source parcel shall be shown. If the adjacent parcel is a street, the name of the street is sufficient. The opposite limit of the street is not required. *Sufficient information shall be shown to give a geographical location to the survey.*

*Adjacent Info.*

**NOTE** *Excessive reference information outside the source parcel that is not required to provide a geographical location will not be examined for its correctness.*

10. At minimum, portions of all parcels (including Metes and Bounds plans) immediately adjacent to any survey tie lines shall be shown. Breaks in the tie lines may be used to eliminate some drafting in these situations as long as it is clear as to the location of the tie line.

*Tie Lines*

11. **The standard lettering size shall be:**

|                     |        |
|---------------------|--------|
| Heading             | 6.0 mm |
| Legend              | 2.5 mm |
| Survey Information  | 2.5 mm |
| Section Numbers     | 6.0 mm |
| Twp, Rge, Mer       | 4.0 mm |
| Area                | 4.0 mm |
| Site Names          | 6.0 mm |
| Street Names        | 2.5 mm |
| Lot Identifiers     | 2.5 mm |
| Block Identifiers   | 4.0 mm |
| Parcel Identifiers  | 4.0 mm |
| Approved/registered |        |
| Plan Numbers        | 3.0 mm |

*Text Sizes*

12. Where there is a change in Township or Range, the Township or Range lines shall be clearly identified on each side of the road allowance.

*Twp & Rge*

i.e.: **Twp 25** or **Rge 12**

*LLDs*

13. The legal land description (LLD) along with a new extension number for all the remaining portions of the source parcels shall be displayed.

a) The Quarter Sections affected by the new survey shall be completely described and shown as follows:

i) at centre of section

|  
**-23 -** - section number: 6 mm (standard)  
**26-12-3** - location: 4.0 mm (standard)  
|

ii) ¼ designation: **NE 23-26-12-W 3 Mer – Ext. 1**  
(4.0 mm standard)

b) Parcels or lots affected by the new survey shall be completely described and shown as follows:

i) Parcels: **A – Ext. 1** - 4.0 mm (standard)

ii) Lots: **1 – Ext. 1** - 2.5 mm (standard)

14. In preparing a plan of survey for abbreviations, Section 13(1) of *The Land Surveys Regulations*, shall apply

*Abbreviations*

15. The top of the plan shall be north. A north arrow shall be placed in a conspicuous position and shall clearly indicate the direction north. All information should be readable from the bottom or bottom right corner of the plan to ensure consistency in the placement of the text.

*North  
Arrow*

---

# General Plan Requirements

## Legends

1. Most plans shall have a legend. The following are the suggested contents:
  - a) Standard road allowances on this plan are 20.117 (or 30.175) metres in width. This note may be omitted if the widths of the road allowances are clearly shown on the plan proper.
  - b) Measurements are in metres and decimals thereof.
  - c) The unique identifier number of S (number) for the survey firm has been stamped on all established standard iron posts.
  - d) Area to be approved is outlined with a heavy dashed line.
  - e) For surface or mineral plans, a note should be added to the legend stating, "All parcels within the line of approval have an extension 0 unless otherwise shown." (This does not apply to feature plans).
  - f) For feature plans, a note may be added to the legend stating, "The extensions of all parcels affected by this feature are 0 unless otherwise shown."
  - g) For feature plans, a note should be added to the legend stating, "New Right of Way limits are straight lines unless otherwise shown". This may eliminate the need to show some angles in congested areas.
  - h) For feature plans, a note may be added stating, "Monuments established along the right of way limit are marked "RW" (or the initial letters of the words composing the name of the company that has the interest in the right of way) and shown thus ...•."
  - i) For feature plans or where applicable, a note may be added stating, "Width of right of way is \_\_ unless otherwise shown."
  - j) Standard iron posts (or Standard Monuments or Monuments as the case may be) found are shown thus-----◆.
  - k) Standard iron posts (or Standard Monuments or Monuments as the case may be) planted are shown thus -----●.

*Legends*

It should be noted that the definitions in the new Act speak only to the physical traces of a monument. For example:

If there is no physical trace of a monument and you re-establish the monument from plan information, you are in fact re-establishing the location of the monument not the original monument itself. In this case the plan information you used is considered as **evidence** of the original monument's **location**. Your plan would then have a notation stating that the monument was lost and that the location was re-established using plan information

## Examples of Plan Notations

### Original Monuments

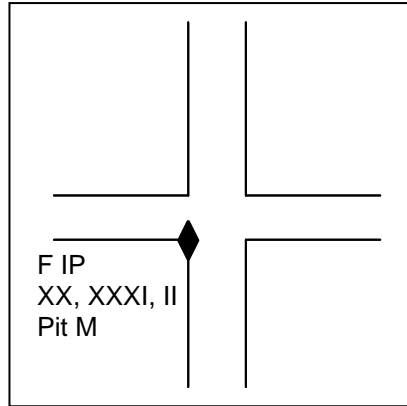
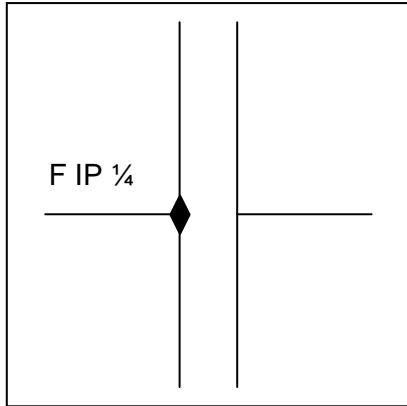

### Deteriorated Monuments

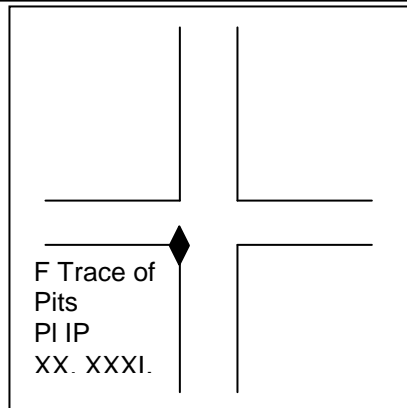
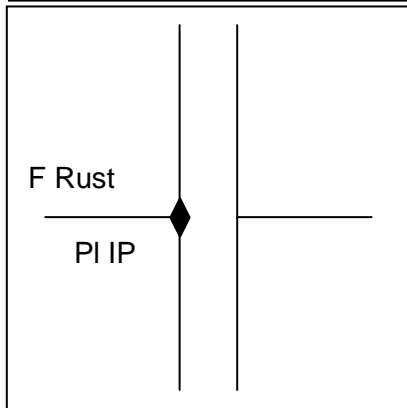

### Lost Monuments

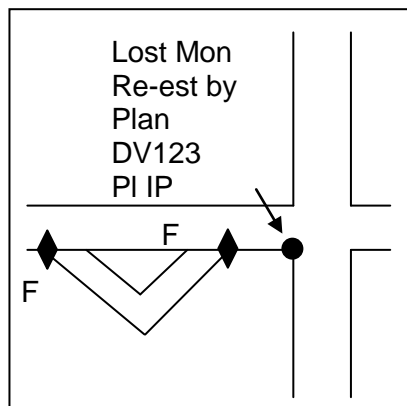
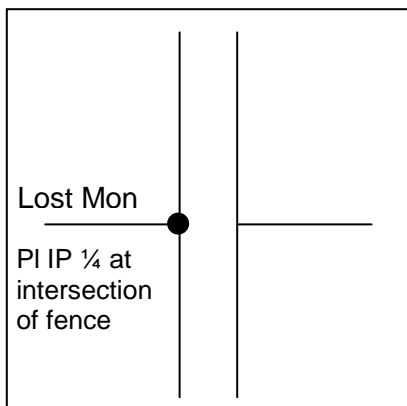

**NOTE** *If reference is made to “Monuments found (or planted) are shown...” in the legend, then all monuments shown on the plan shall be labeled as to the type of monuments found (or planted) and their markings.*

**NOTE** *Text style Descriptive Plan Type II plans do not require a legend.*

## Monuments

2. a) Complete information shall be shown as to the type, markings, condition and position of monuments found. The markings on found Brass Caps do not need to be shown. However the year in which it was established is required (e.g. F.P. 1965 or F.P. 1965 at ¼).
- b) Sufficient information shall be shown to clearly define the manner in which a monument has been re-establishment.
- c) Where informal referencing is used, the monument notation on the plan shall show the date of reference and date of re-establishment.  
e.g.  
FIP – June 1, 1998  
Destroyed by construction  
PIIP Mr. – Sept 1, 1998

*Monument  
Info.*

## Details

3. a) Where sufficient space does not exist on the plan proper, the information may be shown on a detail, drawn to a size that is sufficient to clearly show the information. The detail does not have to be drawn to scale. However, it must be drawn proportionately so it is very clear as to its survey content.
- b) Wherever possible, all details shall be drawn outside of the source parcel.
- c) Wherever possible, details shall be numbered or lettered in a consecutive manner and shown adjacent to the affected parcel.
- d) Where sufficient space exists, to link plan proper and detail together, monuments and angles shall be shown on the plan proper, and a notation indicating “See Detail \_\_\_\_” to coincide with the letter or number assigned to the detail.

*Details*

# Curve Information

4. a) **Curves (minimum requirements)**

Curves

Subdivision curves shall show separate arc information for each lot, parcel, etc. The total Delta, total Sub-tangent and radius of the total curve is required to be shown.

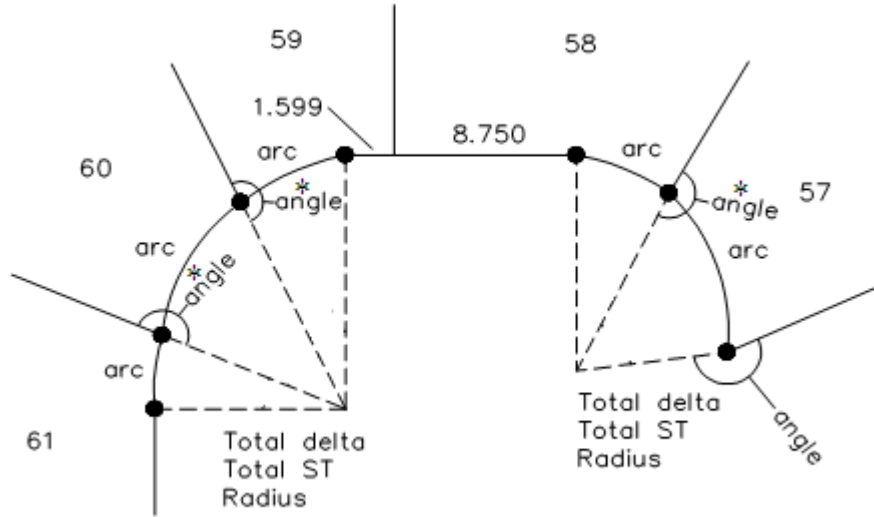

\* Angle from lot line to radius when not 180°; preferred, but not mandatory.

b) Curve information shall be shown as follows: (note the arc shall be shown adjacent to the curve in all cases)

a) Simple curves

- $\Delta$  . . . . Deflection angle between Sub-tangents (Delta)
- ST . . . . Sub-tangent
- R . . . . Radius

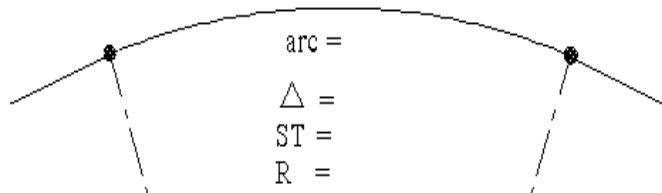

- b) Replacement of planned or constructed spiral curves shall show three simple curves and shall include the total Deflection Angle ( $T\Delta$ ) and total sub-tangent (TST).

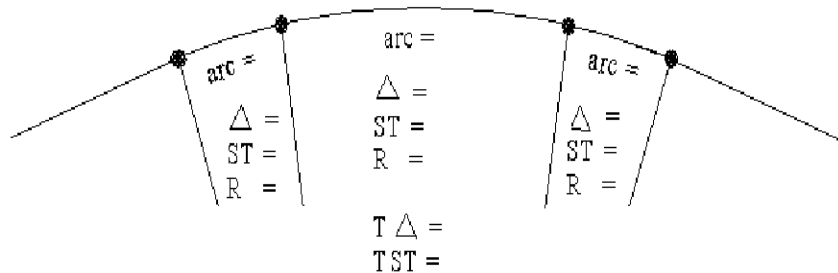

- c) Retracement of existing replacement curves based on **prescribed** tables (Arc definition for roads and Chord definition for railways) shall show three simple curves and shall include the Total Sub-tangent (TST) and Total Delta ( $T\Delta$ ).

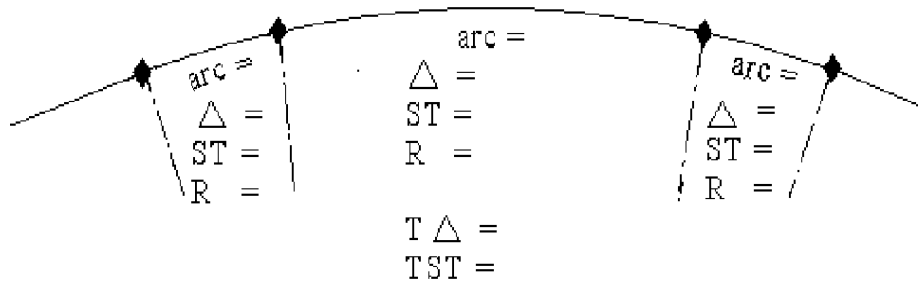

- ii) When intersecting an existing curve or when it is necessary to re-establish one end of a curve, a minimum of two curve monuments and one tangent shall be found or re-established to verify the existing curve information. Curve intersection measurements to survey lines shall include:
- Distance from BC and/or EC to intersection on sub-tangent or chord.
  - Angle with sub-tangent or chord at intersection.
  - Distance from the intersection on sub-tangent or chord to intersection of curve.

## Areas

5. a) Areas on right of way (feature plans) shall be shown to the second decimal point within the source parcel.

Areas

 NOTE

*For more information on showing road areas, contact the ISC Customer Support Team at 1-866-275-4721 or at [ask@isc.ca](mailto:ask@isc.ca).*

## Parcel Designations

6. a) All new parcels shall have a parcel or lot/block identifier, usually shown as letter(s) or number(s). However some identifiers require a combination of both. These include the following:

Parcel  
Designations

- Streets - S#.
- Street Intersections – SX#
- Lanes – L#
- Public Reserves – PR#
- Municipal Reserves – MR#
- Walkways – W#
- Environmental Reserves – ER#
- Municipal Environmental Reserves – MER#
- Buffer Strips – PB#
- Municipal Buffer Strips – MB#

 NOTE

*For more information on showing parcel identifiers on road plans, contact the ISC Customer Support Team at 1-866-275-4721 or at [ask@isc.ca](mailto:ask@isc.ca).*

 NOTE

***When dedicated lands, such as MR, MER & MB, are created in the name of a municipality (urban or rural), the name of that municipality shall be displayed on the plan as stated in The Dedicated Lands Regulations. In most cases the municipalities name would be displayed in the title block.***

b) When streets, street intersections and lanes are created, the resulting parcels shall be assigned unique identifiers as mentioned above. The street intersections are shown as fine dashed lines and the ends of lanes are closed off with solid lines. If a street is continuous but the street name changes at a designated dividing line, the client shall indicate this dividing line on their plan with a fine dashed line and assign unique street identifiers to the parcels on both sides of the dividing line.

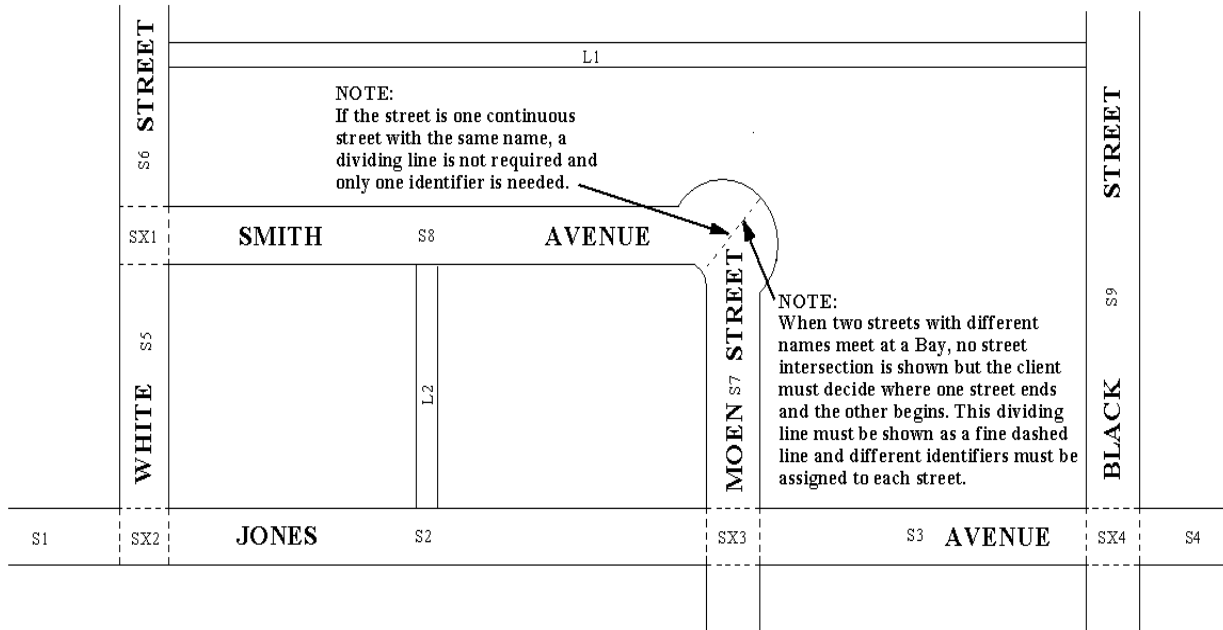

 **NOTE** *Every effort shall be made so as not to duplicate Parcel Identifiers within the Quarter Section or Block.*

- c) Road widenings on subdivision plans shall be given a parcel identifier. If the new road widening is adjacent to a street, it is considered an extension of that street so it should be given an identifier of S#. The road widening shall also be labeled with the street name. If the new road widening is adjacent to a road allowance or road plan it is considered an extension of the road and therefore should be given a parcel designator of A, B, C, etc. or G as shown below. Road widenings on any plan other than a road plan shall be labeled “**Road Widening**”.

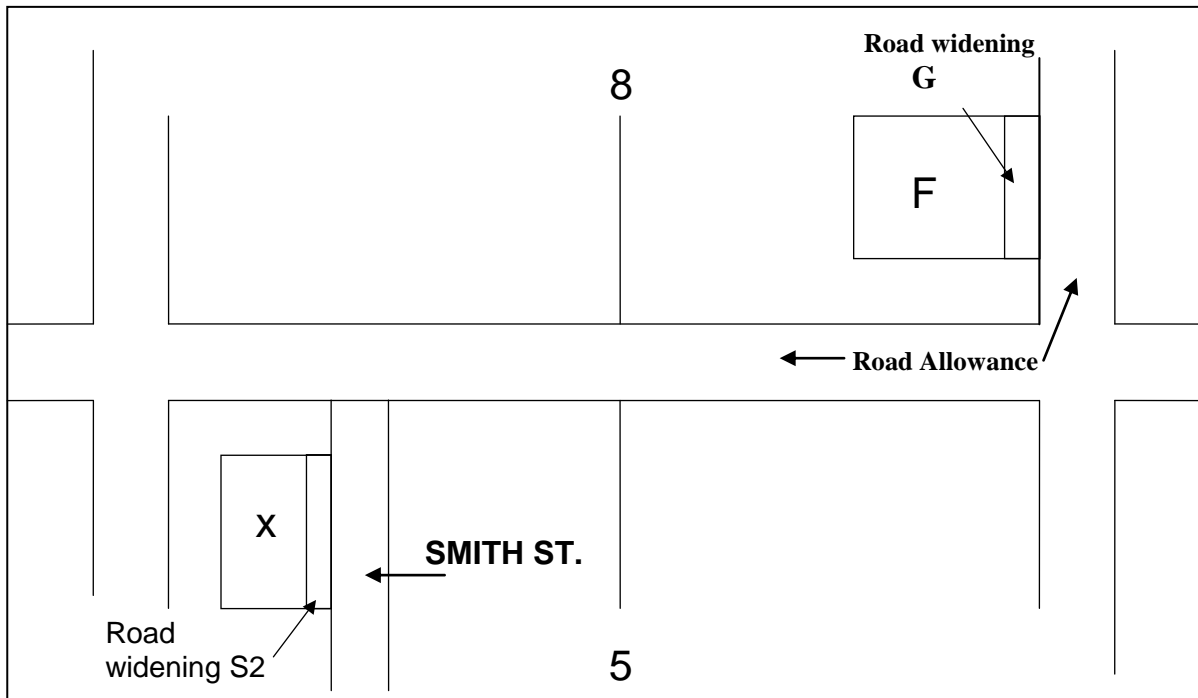

- d) On feature plans, a unique parcel designator in the form of a letter may be assigned to the new right-of-way within each source parcel. The lettering shall be consecutive and unique throughout the plan.

## Natural Boundaries

7. The character of any natural feature adopted as a boundary shall be designated clearly and concisely on the plan. In the case of water boundaries, except where applicable legislation, judicial decisions or existing rights are to the contrary, use “bank” as defined in Section 32 of *The Land Surveys Regulations* as the feature defining the boundary.

Water

- a) A note shall be shown on the plan stating “The bank is taken as the boundary. For the definition of bank, see Section 32 of *The Land Surveys Regulations*”.
- b) A note shall be added to the plan, adjacent to the bank, to clearly indicate the method used to establish the bank. e.g.: “The bank was plotted from Township Plat dated \_\_\_\_\_” **or** “The bank was plotted from 1:60,000 Aerial Photography (Photo ISC 80482-033 L-16)” **or** “The bank was plotted from Plan No. \_\_\_\_\_”.
- c) Where it is necessary to define the bank at the time of the current survey, measurements are to be shown at each change in direction to adequately define the bank.

## Miscellaneous

- 8. Street names shall be displayed where portions of urban areas are shown. *Street Names*
  
- 9. Condominium plans, shown for reference information, should be labeled “Condominium Plan No. \_\_\_\_\_” with the underlying subdivision plan number shown in brackets. *Condos*

e.g.: Condominium Plan No. 99RA05654  
(Plan No. 96R68343)
  
- 10. When railway right of ways or railway station grounds form part of the source parcel, the centreline of the railway is not required. However, if the centreline is shown it shall be shown as a faint dashed line so as not to be confused with the heavy dashed approval line. *Railways*
  
- 11. The perpendicular width of new right of way (feature) plans shall be shown clearly. The perpendicular width of other roads, streets, lanes and right of ways in the vicinity shall be shown. *Widths*
  
- 12. Angles shall be shown on new Right of Way limits at all intermediate monuments. In congested areas, a statement may be placed in the legend stating “New Right of Way limits are straight lines unless otherwise shown” to eliminate the need to show some angles on the new Right of Way limits. *Angles on ROWs*

13. A sufficient number of angles shall be shown at all intersections to clearly indicate whether or not a deflection exists at the intersection. All linear measurements are required in all directions from the point of intersection.

*Intersections*

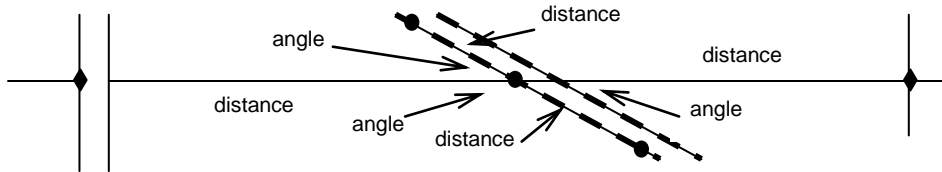

14. Angular and linear measurements are required for each connection to an existing boundary.

*Common Monuments*

15. When common monuments are shown on multiple plans surveyed by the same surveyor during the same time period, one plan shall show the monuments as planted and the remaining plans shall show them as found.

16. The plan shall only show approved plans. If measurements are shown to monuments established on an unapproved plan, the plan shall be in the Land Surveys Directory and the notation "Unapproved" shall be shown with the plan number. Easement Instruments or registered interests shall not be shown on any plan if it is not represented by a plan within the Land Surveys Directory

*Approved Plans Only*

17. When it is necessary to re-establish monuments required for the new survey, angular and linear measurements are required from the re-establishment to the new survey.

*Connections To Other Surveys*

**Example A**

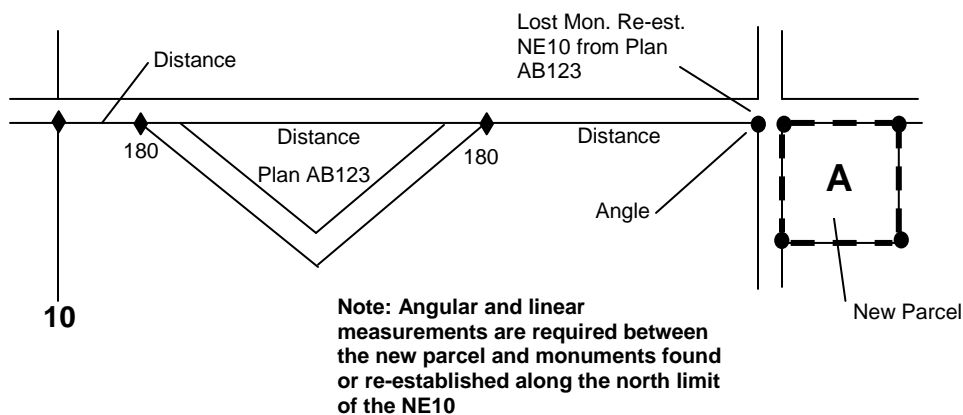

**Example B**

